

V.F. # 964-4" BRONZE BILGEMATE PERIPHERAL – JET EDUCTOR

STANDARD COMMERCIAL MODEL 2½" x 4" x 4"

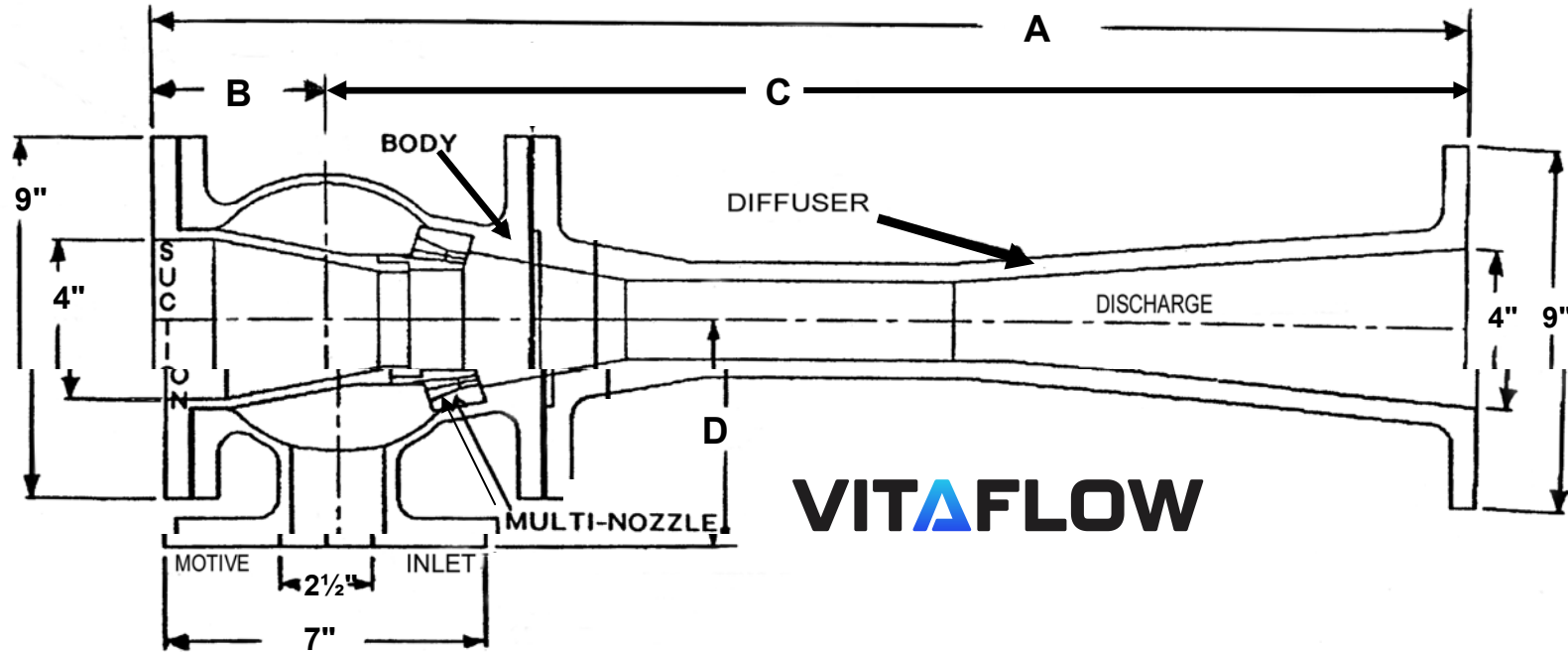

MATERIALS OF CONSTRUCTION:

Body & Diffuser: Bronze ASTM B62
 Multi-Nozzle: Monel
 Fasteners: 316 Stainless Steel
 Gaskets: Neoprene

General Specifications:

Suction Capacity Up to 250 GPM (57 M3/H)
 Suction Lift Up to 20 Feet (-6 Meters)
 Discharge Head Up to 70 Feet (22 Meters)
 Inlet Pressure 75 - 150 PSI (5 - 10 Bar)
 Inlet Quantity 150 - 250 GPM (34-57 M3/H)

FLANGES 150 lb ANSI B16.24 FLAT FACE

SIZE	Inside Diameter	Outside Diameter	Bolt Circle	No. Holes	Hole Diameter
INLET	2½"	7"	5½"	4	.750"
SUCTION	4"	9"	7½"	8	.750"
DISCHARGE	4"	9"	7½"	8	.750"

Dimensions:

Inlet	Suction.	Discharge	"A"	"B"	"C"	"D"	Weight
2½"	4"	4"	23"	4.375"	18.625"	5.687"	90 lbs