

# V.F. # 974 – 4" BRONZE BILGEMATE EDUCTOR

STANDARD COMMERCIAL MODEL

3" x 4" x 4"

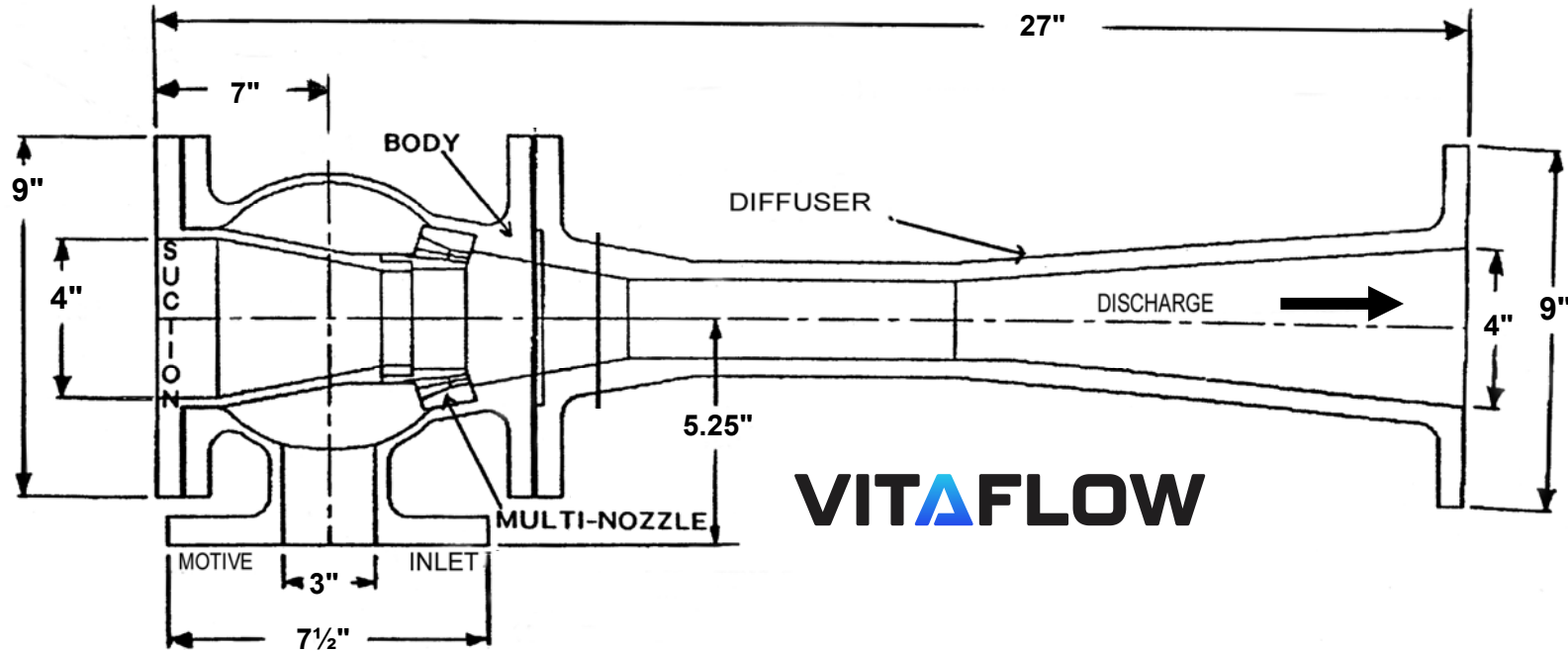

**VITAFLOW**

**Materials of Construction:**

Body & Diffuser – Bronze ASTM B62  
 Multi-Nozzle 316 Stainless Steel

**General Specifications**

Suction Lift Up to 20 Feet  
 Discharge Head Up to 80 Feet  
 Inlet Pressure 50 - 150 PSI  
 Inlet Quantity 150 – 250 GPM  
 Suction Capacity Up to 350 GPM

**Flanges:** 150 lb ANSI B16.24 Flat Face

	<u>O.D.</u>	<u>I.D.</u>	<u>THICK</u>	<u># HOLES</u>	<u>DIAMETER</u>	<u>BOLT CIRCLE</u>
<u>INLET</u>	7 1/2"	3"	9/16"	4	.750"	6"
<u>SUCTION</u>	9"	4"	11/16"	8	.750"	7 1/2"
<u>DISCHARGE</u>	9"	4"	11/16"	8	.750"	7 1/2"

**Dimensions:**

<u>Inlet</u>	<u>Suction.</u>	<u>Discharge</u>	<u>"A"</u>	<u>"B"</u>	<u>"C"</u>	<u>"D"</u>	<u>Weight</u>
3"	4"	4"	27"	7"	20"	5 1/4"	110 LBS