

# V.F. # 978-8" BRONZE BILGEMATE PERIPHERAL – JET EDUCTOR

STANDARD COMMERCIAL MODEL 5" x 6" x 8"

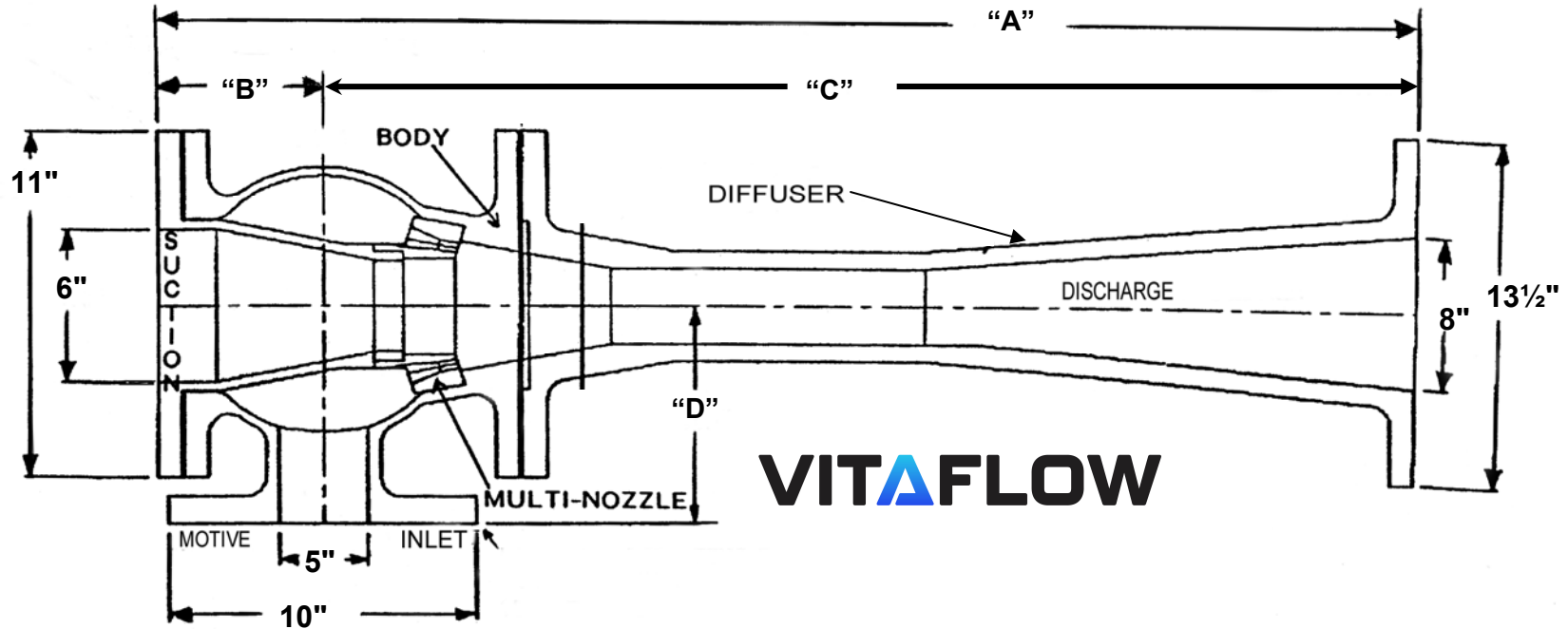

**VITAFLOW**

**Materials of Construction:**

Body & Diffuser – Bronze  
 ASTM B62  
 Multi-Nozzle Monel  
 Fasteners 316 Stainless Steel  
 Gaskets: Neoprene or Garlock Gylon

**General Specifications**

Suction Lift Up to 20 Feet (up to – 6 Meters)  
 Discharge Head Up to 100 Feet (up to 30 Meters)  
 Inlet Pressure Up to 150 PSI (up to 10 Bar)  
 Inlet Quantity 700-1100 GPM (160-250 M3/H)  
 Suction Capacity Up to 1100 GPM (up to 250 M3/H)

**Flanges** 150 lb ANSI B 16.24 Flat Face ( also Available 250 LB Navy, undrilled, DIN, Metric, JIS )

	<u>O.D.</u>	<u>I.D.</u>	<u>THICK</u>	<u># HOLES</u>	<u>Diameter</u>	<u>Bolt Circle</u>
<u>INLET</u>	10"	5"	.687"	8	.875"	8½"
<u>SUCTION</u>	11"	6"	.812"	8	.875"	9½"
<u>DISCHARGE</u>	13½"	8"	.937"	8	.875"	11"

**Dimensions:** Dimensions shown are for Eductor with 250 LB flanges.

<u>Inlet</u>	<u>Suction.</u>	<u>Discharge</u>	<u>"A"</u>	<u>"B"</u>	<u>"C"</u>	<u>"D"</u>	<u>Weight</u>
5"	6"	8"	47"	5"	42"	7.875"	310 lbs